

■ Features

- High Lumen LEDs
- 5mm Round Standard Directivity
- UV Resistant Epoxy
- Water Clear Type

■ Applications

- Electronic Signs And Signals
- Small Area Illuminations
- Back Lighting
- Other Lighting

■ Outline Dimension

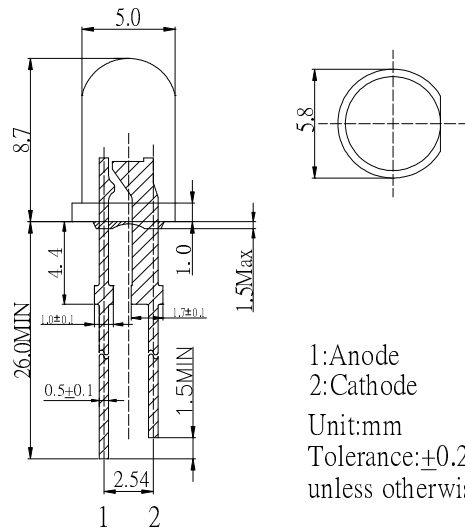

■ Absolute Maximum Rating (Ta=25°C)

Item	Symbol	Value	Unit
DC Forward Current	I _F	80	mA
Pulse Forward Current#	I _{FP}	120	mA
Reverse Voltage	V _R	5	V
Power Dissipation	P _D	288	mW
Operating Temperature	T _{opr}	-30 ~ +85	°C
Storage Temperature	T _{stg}	-40 ~ +100	°C
Lead Soldering Temperature	T _{sol}	260°C/5sec	-

■ Directivity

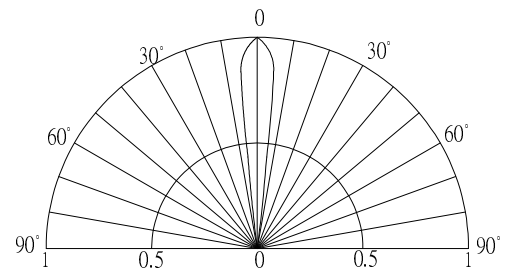

#Pulse width Max.10ms Duty ratio max 1/10

■ Electrical -Optical Characteristics (Ta=25°C)

Item	Symbol	Condition	Min.	Typ.	Max.	Unit
DC Forward Voltage*1	V _F	I _F =75mA	2.8	3.2	3.6	V
DC Reverse Current	I _R	V _R =5V	-	-	10	μA
Luminous Flux*2	Φ _v	I _F =75mA	4	5	-	lm
Luminous Intensity*3	I _v	I _F =75mA	43000	50000	-	mcd
Domi. Wavelength*4	λ _D	I _F =75mA	465	470	475	nm
50% Power Angle	2θ _{1/2}	I _F =75mA	-	15	-	Deg

■ Spectral Curve

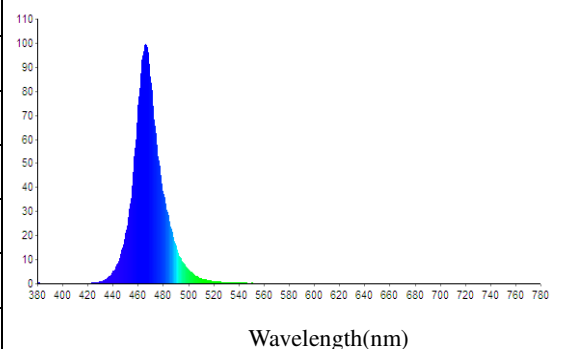

*1 Tolerance of measurements of forward voltage is ±0.1V

*2 Tolerance of measurements of luminous flux is ±15%

*3 Tolerance of measurements of luminous intensity is ±15%

*4 Tolerance of measurements of dominant wavelength is ±1nm