

SPECIFICATION FOR APPROVAL 樣品承認書

PAGE : OF

3L P/N : TC-182M-1A-9026

YOUR REF.:

1.MECHANICAL DIMENSIONS (外形尺寸): DRAW NO.: TC

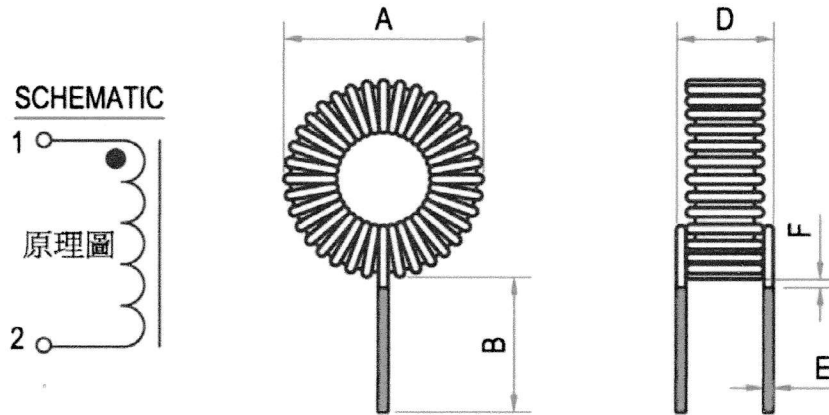

Item項目	Spec.(規格mm)	Typ.(參考值)	Item項目	Spec.(規格mm)	Typ.(參考值)
A	28.0 MAX	26.2	F	1.5 MAX	
B	15.0 +- 3.0	15.0	G		
C			H		
D	14.0 MAX	11.9	I		
E	0.45 +- 0.05	0.45	J		



2. NOTES (備注, 包括印字及起始同相端等特別要求):

2.1 Marking (印字): ""

CUSTOMER	APPROVED (客戶確認)	APPROVED(確認)	CHECKED(檢查)	DRAWN(制圖)

ISSUED DATE(出版日期): 1996/06/07 PRINT DATE(出圖日期): / / REV(版次):1C

SPECIFICATION FOR APPROVAL 樣品承認書

		PAGE :      OF		
3L P/N : TC-182M-1A-9026		YOUR REF.:		
<b>3. ELECTRICAL CHARACTERISTICS (電特性要求) :</b>				
Item (項目)	Specifications (規格)	Typ.(參考值)	Test equipments (測試設備) :	
L	1.8mH +- 20%	1.83mH	CHENHWA 100-LCR METER	
Test Freq.	@1kHz 0.25V		CHENHWA 100-LCR METER	
DCR	0.68Ω MAX	0.518Ω	CHENHWA 502 OHM METER	
R.Current	1.0A		HP4284A WITH HP42841A CURRENT SOURCE	
Turns	148Ts REF			
Ope.Temp.	-20 TO 80°C		HC-D3M TEMP. & HUMIDITY CHAMBER	
Weight	23.26g/pcs			
ELECTRICAL NOTES (電特性備注欄) :				
		APPROVED(確認)	CHECKED(檢查)	DRAWN(制圖)
				
ISSUED DATE(出版日期): 1996/06/07    PRINT DATE(出圖日期):    /    /    REV(版次): 1C				