

1W, Fixed input voltage , isolated & regulated single output



Continuous Short Circuit Protection

Patent Protection RoHS

## FEATURES

- Continuous short circuit protection
- Efficiency up to 75%
- Operating temperature range: -40°C to +85°C
- Isolation voltage: 1.5K VDC
- Miniature SMD package
- No external component required
- International standard pin-out

IB\_XT-1WR2 series is specially designed for applications where an isolated voltage is required in a distributed power supply system. It is suitable for

1. Where the voltage of the input power supply is stable (voltage variation:  $\pm 5\%V_{in}$ );
2. Where isolation is necessary between input and output (isolation voltage  $\leq 1500VDC$ );
3. Where has high requirement of line regulation and load regulation.

## Selection Guide

Part No.	Input Voltage (VDC)	Output		Efficiency (%Min./Typ.) @ Full Load	Max. Capacitive Load ( $\mu F$ )
	Nominal (Range)	Output Voltage (VDC)	Output Current (mA) (Max./Min.)		
IB0503XT-1WR2	5 (4.75-5.25)	3.3	243/25	54/58	220
IB0505XT-1WR2		5	200/20	68/72	
IB0512XT-1WR2		12	84/9	69/73	
IB0515XT-1WR2		15	67/7	70/74	
IB1205XT-1WR2	12 (11.4-12.6)	5	200/20	69/73	
IB1212XT-1WR2		12	84/9	69/73	
IB1215XT-1WR2		15	67/7	71/75	
IB2405XT-1WR2	24 (22.8-25.2)	5	200/20	69/73	
IB2412XT-1WR2		12	84/9	69/73	

## Input Specifications

Item	Operating Conditions	Min.	Typ.	Max.	Unit
Input Current (full load / no-load)	5V input	--	270/15	--	mA
	12V input	--	115/10	--	
	24V input	--	56/7	--	
Surge Voltage (1sec. max.)	5V input	-0.7	--	9	VDC
	12V input	-0.7	--	18	
	24V input	-0.7	--	30	
Reflected Ripple Current		--	15	--	mA
Input Filter		Capacitor filter			

## Output Specifications

Item	Operating Conditions	Min.	Typ.	Max.	Unit
Output Voltage Accuracy	100% load	--	--	$\pm 3$	%
Line Regulation	Input voltage change: $\pm 1\%$	--	--	$\pm 0.25$	
Load Regulation	10%-100% load	3.3VDC output	--	3	
		Other output	--	2	
Ripple*	20MHz bandwidth	--	10	--	mVp-p
Noise*		--	50	--	
Temperature Drift Coefficient	100% load	--	--	$\pm 0.03$	%/°C
Output Short Circuit Protection		Continuous, self-recovery			

Note: \* Ripple and noise tested with "parallel cable" method, please see DC-DC Converter Application Notes for specific operation methods.

### General Specifications

Item	Operating Conditions	Min.	Typ.	Max.	Unit
Isolation Voltage	Input-output, with the test time of 1 minute and the leak current lower than 1mA	1500	--	--	VDC
Isolation Resistance	Input-output, isolation voltage 500VDC	1000	--	--	MΩ
Isolation Capacitance	Input-output, 100KHz/0.1V	--	20	--	pF
Operating Temperature	Derating when operating temperature up to 71°C, (see Fig. 1)	-40	--	85	°C
Storage Temperature		-55	--	125	
Casing Temperature Rise	Ta =25°C	--	25	--	
Pin Welding Resistance Temperature	Welding spot is 1.5mm away from the casing, 10 seconds	--	--	300	
Reflow Soldering Temperature		Peak temp. ≤245°C, maximum duration time ≤60s at 217°C. For actual application, please refer to IPC/JEDEC J-STD-020D.1.			
Storage Humidity	Non-condensing	--	--	95	%
Switching Frequency	100% load, nominal input voltage	--	100	300	KHz
MTBF	MIL-HDFK-217F@25°C	3500	--	--	K hours

### Physical Specifications

Casing Material	Black flame-retardant heat-proof epoxy resin (UL94-V0)
Package Dimensions	15.24*11.20*7.25 mm
Weight	2.0g (Typ.)
Cooling Method	Free air convection

### EMC Specifications

EMI	Conducted disturbance	CISPR22/EN55022	CLASS B (see Fig. 3 for recommended circuit)
	Radiated emission	CISPR22/EN55022	CLASS B (see Fig. 3 for recommended circuit)
EMS	Electrostatic discharge	IEC/EN61000-4-2	Contact ±6KV perf. Criteria B

### Product Characteristic Curve

Temperature Derating Graph

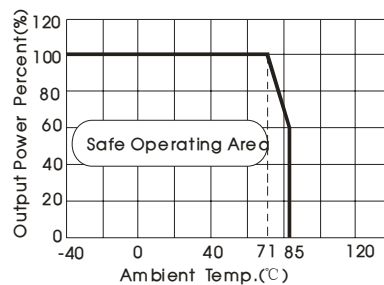
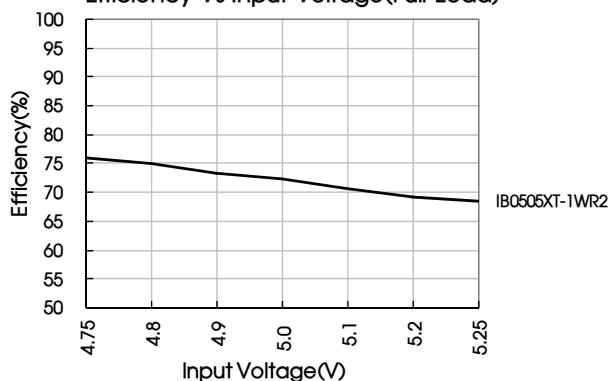
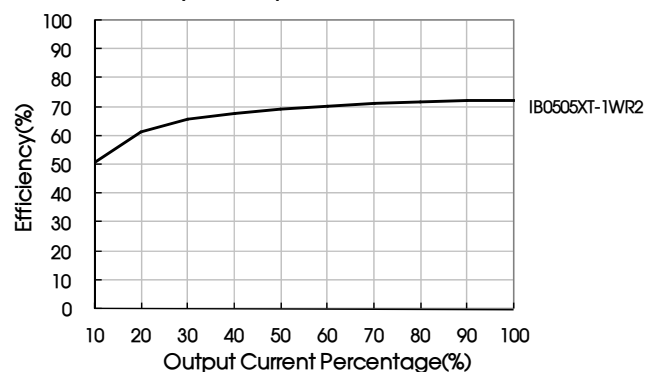

Fig. 1

Efficiency Vs Input Voltage(Full Load)



Efficiency Vs Output Load(Vin=5V)



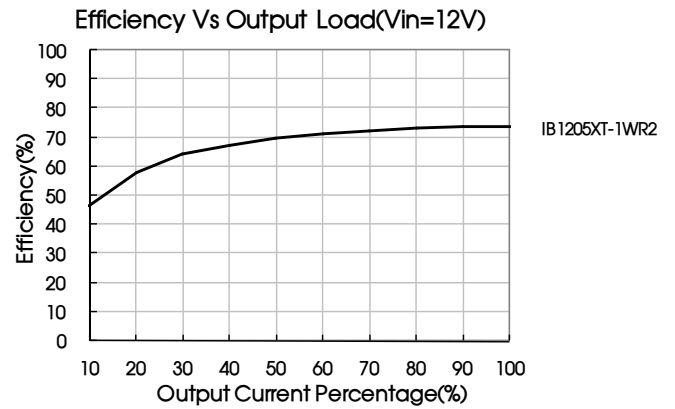
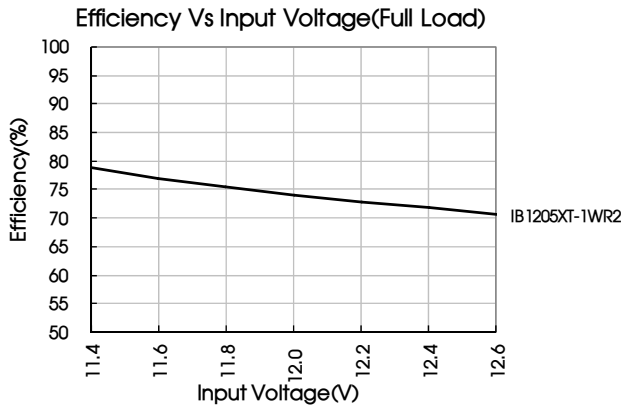

Design Reference

1. Typical application

If it is required to further reduce input and output ripple, a filter capacitor can be connected to the input and output terminals, see Fig.2. Moreover, choosing suitable filter capacitor is very important, start-up problems may be caused by too large capacitance. To ensure the modules running well, the recommended capacitive load values as shown in Table 1.

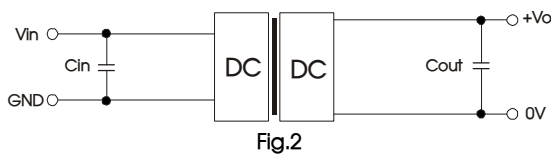

Recommended capacitive load value table (Table 1)

Vin(VDC)	Cin(μF)	Vo (VDC)	Cout(μF)
5	4.7	3.3/5	10
12	2.2	12	2.2
24	1	15	1

It is not recommended to connect any external capacitor when output power is less than 0.5W.

2. EMC typical recommended circuit

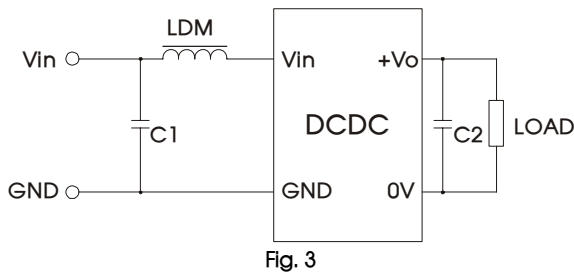

Input voltage (V)		5/12/24
EMI	C1	4.7μF /50V
	C2	Refer to the Cout in Fig.2
	LDM	6.8μH

Note: It is not needed to add the component in the peripheral circuit when parameter with the symbol of "-".

3. Output load requirements

To ensure the module work efficiently and reliably, during the operation, the min. output load should be no less than 10% of the full load. If the actual output power is low, please connect a resistor to the output terminal in parallel, with a recommended resistance which is 10% of the rated power, and derating is required during operation.

4. For more information please find the application notes on [www.mornsun-power.com](http://www.mornsun-power.com)

Dimensions and Recommended Layout

THIRD ANGLE PROJECTION 

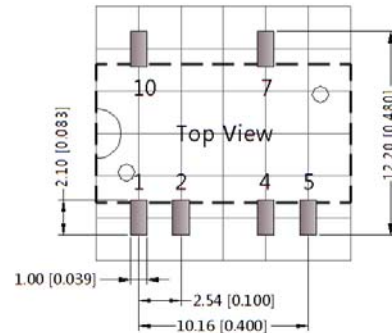
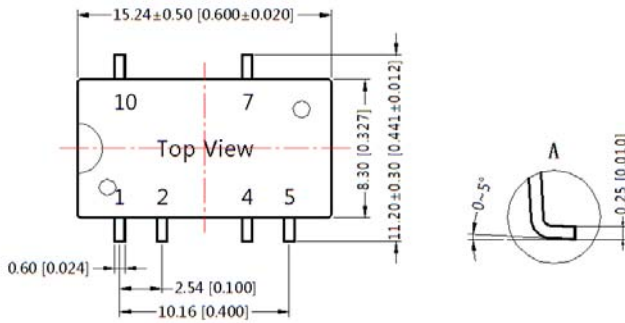

Note: Grid 2.54\*2.54mm

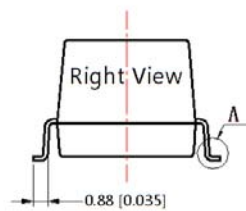
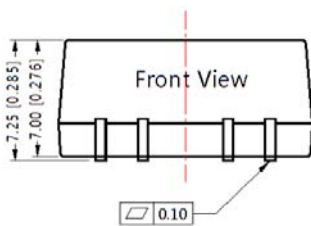

Note:  
Unit: mm[inch]  
Pin section tolerances:  $\pm 0.10[\pm 0.004]$   
General tolerances:  $\pm 0.25[\pm 0.010]$

Pin-Out	
Pin	Function
1	GND
2	Vin
4	0V
5	0V
7	+Vo
10	NC

NC: No Connection

Notes:

1. Packing Information please refer to 'Product Packing Information'. Packing bag number: 58210023;
2. If the product is operated under the min. required load, the product performance cannot be guaranteed to comply with all performance indexes in this datasheet;
3. The max. capacitive load should be tested within the input voltage range and under full load conditions;
4. Unless otherwise specified, data in this data sheet should be tested under the conditions of  $T_a=25^{\circ}\text{C}$ , humidity<75% when inputting nominal voltage and outputting rated load;
5. All index testing methods in this datasheet are based on our Company's corporate standards;
6. The performance indexes of the product models listed in this manual are as above, but some indexes of non-standard model products will exceed the above-mentioned requirements, and please directly contact our technicians for specific information;
7. We can provide product customization service;
8. Specifications of this product are subject to changes without prior notice.

MORNSUN Guangzhou Science & Technology Co., Ltd.

Address: No. 5, Kehui St. 1, Kehui Development Center, Science Ave., Guangzhou Science City, Luogang District, Guangzhou, P. R. China  
Tel: 86-20-38601850-8801 Fax: 86-20-38601272 E-mail: [info@mornsun.cn](mailto:info@mornsun.cn)