



SPL (Hong Kong) Limited

Rm 2507, 25/F, Prosperity Centre, 25 Chong Yip St., Kwun Tong, Kln., HK.
 Tel: 852-23426867 / 57 Fax: 852-23426847 Email: sales@spl-hk.com.hk
 www.buzzer.com.hk ; www.transducer.com.hk ; www.connector.com.hk

Ultrasonic Sensor SU16 series

NEW CODE SPECIFICATION

DIMENSIONS

Date : 10 Dec, 2005

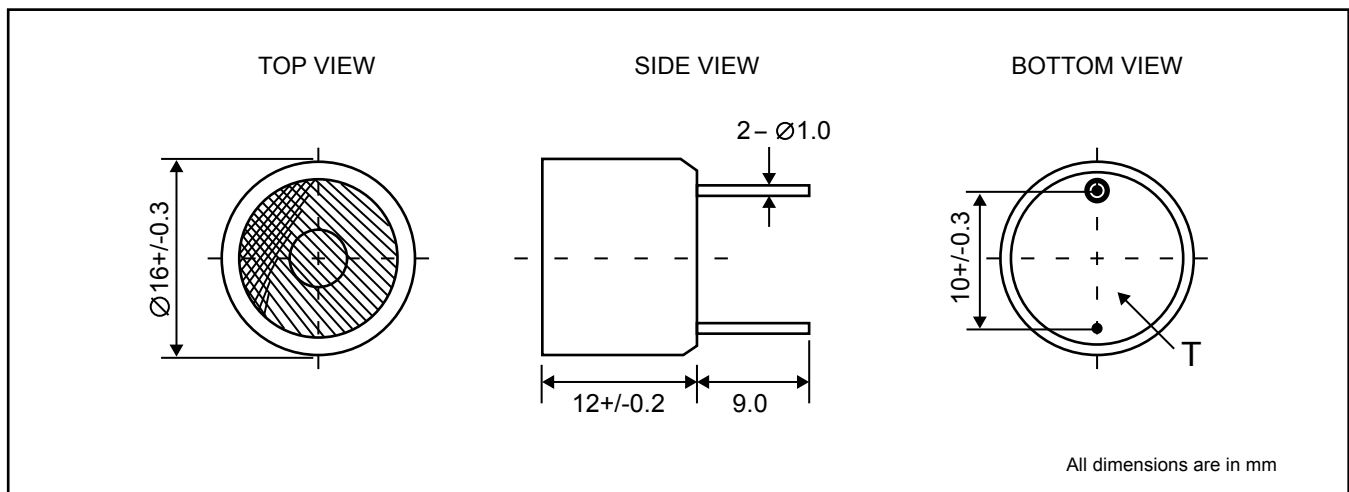

Ref. no.: -

Special Description : UT1612MP to be fulfilled RoHS regulation, (Lead Free version)

ELECTRICAL SPECIFICATIONS

Model No.	UT1612MPR
Construction	Open Structure
Function	Transmitter
Center Frequency <input type="checkbox"/>	[Hz] 40k +/- 1k
Overall Sensitivity <input type="checkbox"/>	[dBA] --
Sound Pressure Level <input type="checkbox"/>	[at 10Vrms, 30cm] 115 dB min. [0dB = 0.02mPa]
-6dB Direction <input type="checkbox"/> <input type="checkbox"/>	[degree] 50 max.
Capacitance <input type="checkbox"/> <input type="checkbox"/>	[at 1kHz] 2400 pF +/- 25%
Max. Input Voltage <input type="checkbox"/>	[Vp-p] 20
Min. Detectable Range <input type="checkbox"/>	[m] 0.2
Max. Detectable Range <input type="checkbox"/>	[m] 4
Terminal	Pin
Housing Material	Aluminium
Colour	Silver
Operating Temperature <input type="checkbox"/>	[°C] -30 ~ +85
Weight <input type="checkbox"/>	[gm] 5