

# 17mm Metal Shaft Rotary Potentiometer - With Switch

**17S1**

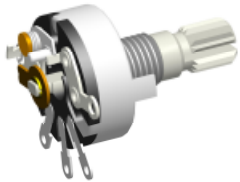

## Part Number

**17S1 – B 10K, L- 20 KC**

Taper

Shaft Length

Resistance value

Shaft Type

## Dimensions

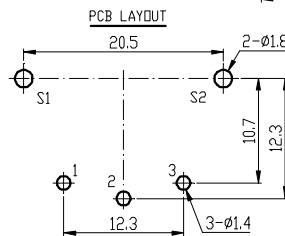
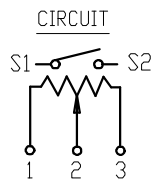
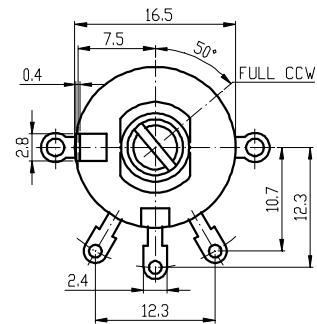
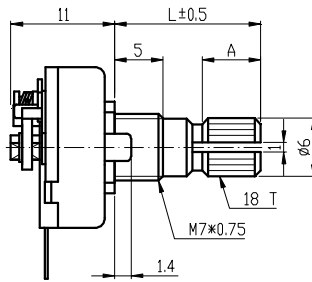
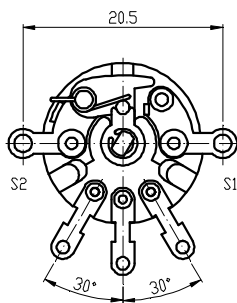

## Shaft Type

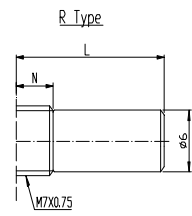
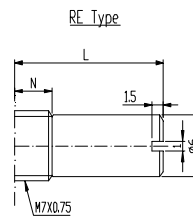
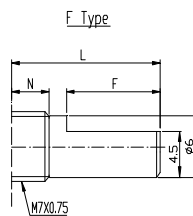
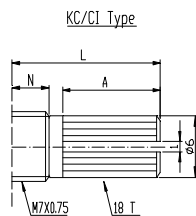
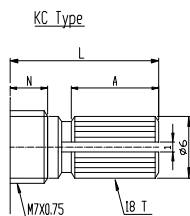

N=5mm

Shaft Type	L	10	12	15	17	20	25	30	35	40
KC	A	3.2		6	8	12	12	12	12	12
	M	0.5		1	1	2	2	4	4	4
KC/CI	A			8		13				
F	F	4	4	7	7	12	12	12	12	12
R,RE	L	10		15	17	20	25	30	35	40

## 17mm Metal Shaft Rotary Potentiometer - With Switch

### General

<b>Operating temperature</b>	<b>-10 °C ~ +70 °C</b>
<b>Manual soldering</b>	<b>300 °C Max 3sec</b>

### Electrical Characteristics

<b>Total resistance</b>	<b>100Ω~2MΩ</b>
<b>Resistance tolerance</b>	<b>±20% (more than 1MΩ ±30%)</b>
<b>Resistance taper</b>	<b>A B C W</b>
<b>Sliding noise</b>	<b>Less than 47 mV</b>
<b>Residual resistance</b>	<b>≤10Ω Max</b>
<b>Switch contact resistance</b>	<b>Less than 20mΩ</b>
<b>Insulation resistance</b>	<b>More than 100 MΩ at DC 500 V</b>
<b>Rated power(W)</b>	<b>Linear (B) taper : 0.1 W Other taper : 0.05 W</b>
<b>Switch rated power</b>	<b>0.5A at DC 12V</b>
<b>Max. Operating voltage</b>	<b>Linear (B) taper : 200 V Other taper : 150 V</b>
<b>Withstand voltage</b>	<b>1 Minute at AC 500 V</b>

### Mechanical Characteristics

<b>Total rotational angle</b>	<b>260 °±10 °(Switch angle: 40 °±5 °)</b>
<b>Rotational torque</b>	<b>30~200 gf.cm</b>
<b>Switch Action</b>	<b>70~350gf.cm</b>
<b>Rotational stopper strength</b>	<b>3 Kgf.cm Min</b>
<b>Shaft push-pull strength</b>	<b>8 Kgf.cm Min.</b>
<b>Rotational life</b>	<b>15,000 Cycles (Switch life: 10,000 Cycles)</b>