



PARA LIGHT ELECTRONICS CO., LTD.

4F, No.1, Lane 93, Chien Yi Road, Chung Ho City, Taipei, Taiwan, R.O.C.

Tel: 886-2-2225-3733

Fax: 886-2-2225-4800

E-mail: para@para.com.tw

<http://www.para.com.tw>

DATA SHEET

PART NO. : A-1001UB

REV : A / 1

CUSTOMER'S APPROVAL : _____

DCC : _____

DRAWING NO. : DS-11-04-0074

DATE : 2005-05-11

Page : 1

PACKAGE DIMENSIONS

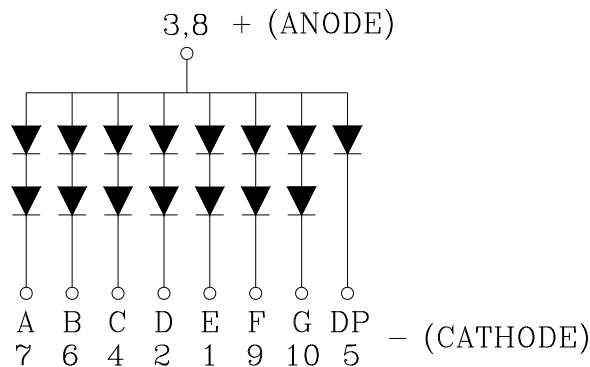
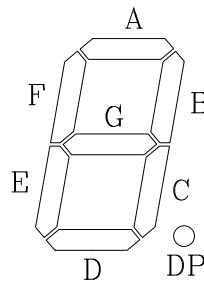
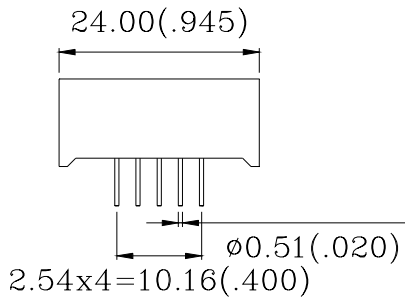
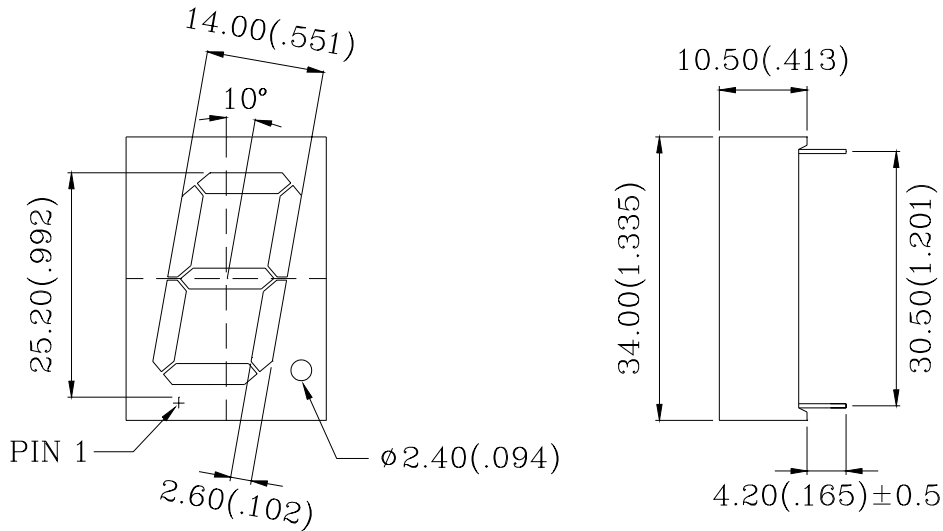

- NOTES :
1. All dimensions are in millimeters. (inches)
 2. Tolerance is $\pm 0.25(0.010)$ " unless otherwise specified.
 3. We would like to offer you samples and mass production after you confirmed the DS and signed to return us

FEATURES

- * 25.20mm (1.00 inch) DIGIT HEIGHT
- * EXCELLENT CHARACTER APPEARANCE
- * COMMON ANODE
- * I.C. COMPATIBLE
- * LOW POWER CONSUMPTION
- * HIGHLIGHT<400V THE LED CAN WITHSTAND THE MAX STATIC LEVEL WHEN ASSEMBLING OR OPERATION

Raw Material : GaInN/GaN

ABSOLUTE MAXIMUM RATING : (Ta = 25°C)

SYMBOL	PARAMETER	ULTRA BLUE	UNIT
PAD	Power Dissipation Per Segment	80	mW
VR	Reverse Voltage Per Segment(DP)	10(5)	V
IAF	Continuous Forward Current Per Segment	10	mA
IPF	Peak Forward Current Per Segment (Duty – 0.1,1KHz)	60	mA
–	Derating Linear From 25°C Per Segment	0.4	mA/°C
Topr	Operating Temperature Range	–35°C to 85°C	
Tstg	Storage Temperature Range	–35°C to 85°C	
Solder Temperature 1/16 inch Below Seating Plane for 5 Seconds at 260°C			

ELECTRO-OPTICAL CHARACTERISTICS : (Ta = 25°C)

SYMBOL	PARAMETER	TEST CONDITION	MIN.	TYP.	MAX.	UNIT
VF	Forward Voltage , Per Segment(DP)	IF = 20mA		7.0(3.5)	8.0(4.0)	V
IR	Reverse Current , Per Segment(DP)	VR = 10 (5)V			100	µA
λP	Peak Emission Wavelength	IF = 20mA		462		nm
λD	Dominant Wavelength	IF = 20mA		470		nm
Δλ	Spectral Line Half – Width	IF = 20mA		30		nm
IV	Luminous Intensity Per Segment	IF = 10mA	20.8	52.0		mcd

FORWARD CURRENT Vs. FORWARD VOLTAGE

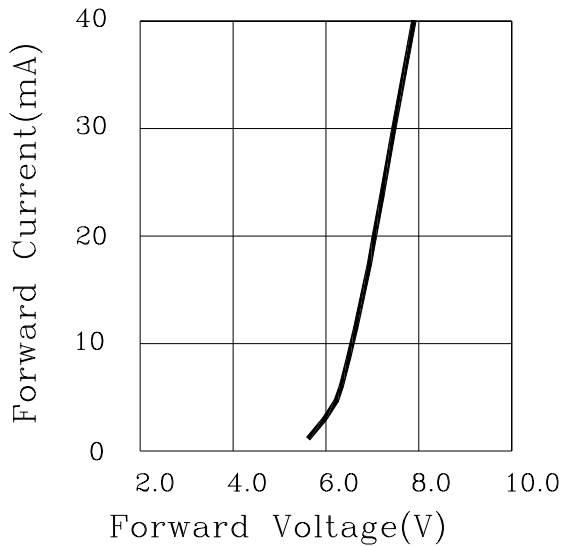

RELATIVE INTENSITY Vs. FORWARD CURRENT

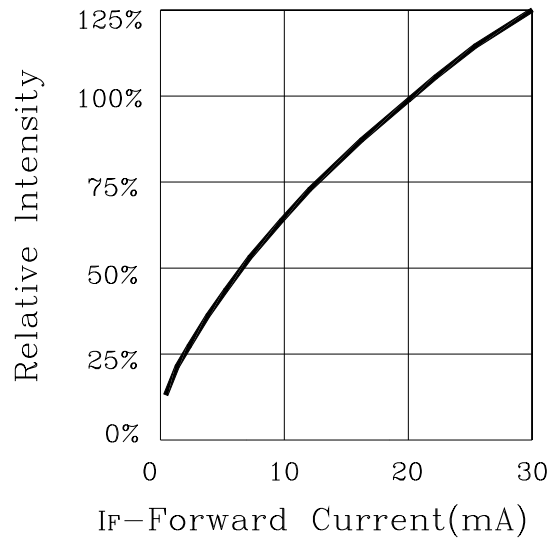

FORWARD CURRENT DERATING CURVE

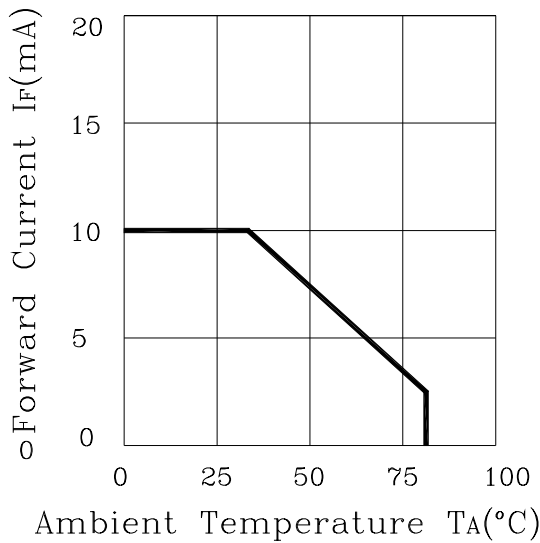

LUMINOUS INTENSITY Vs. AMBIENT TEMPERATURE

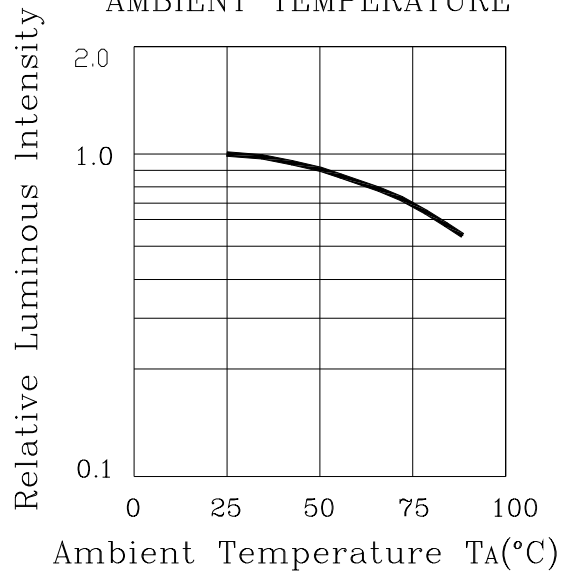

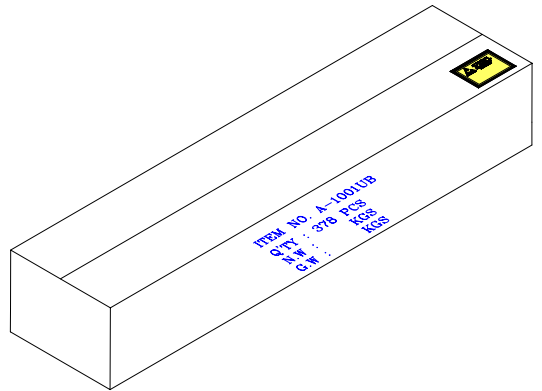
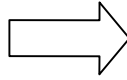
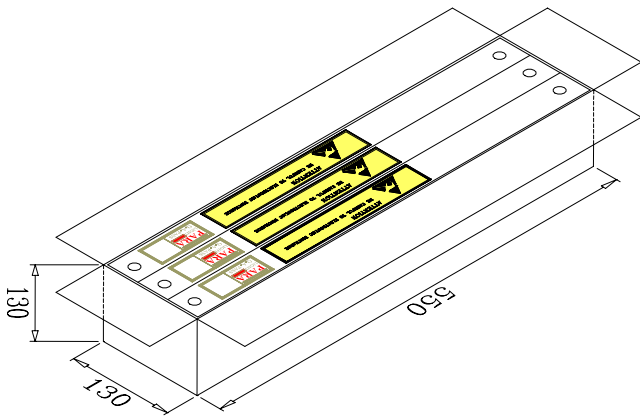
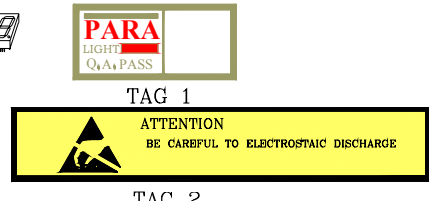
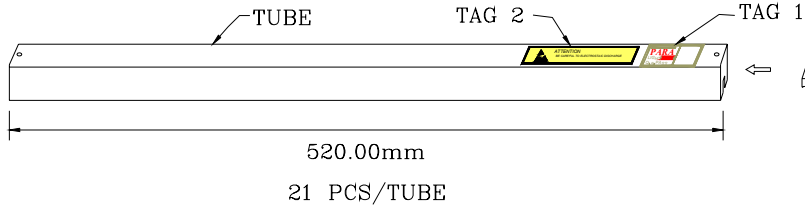

18 TUBE/BOX

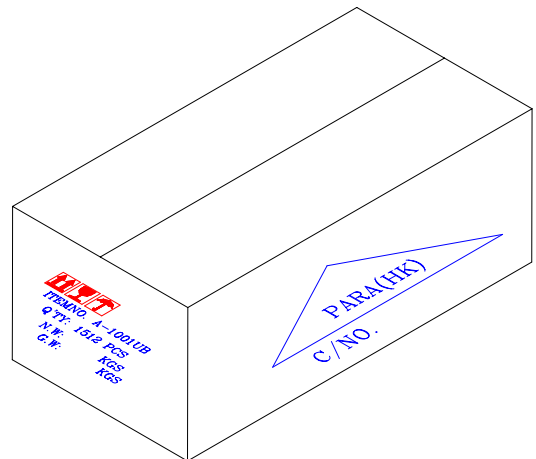
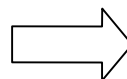
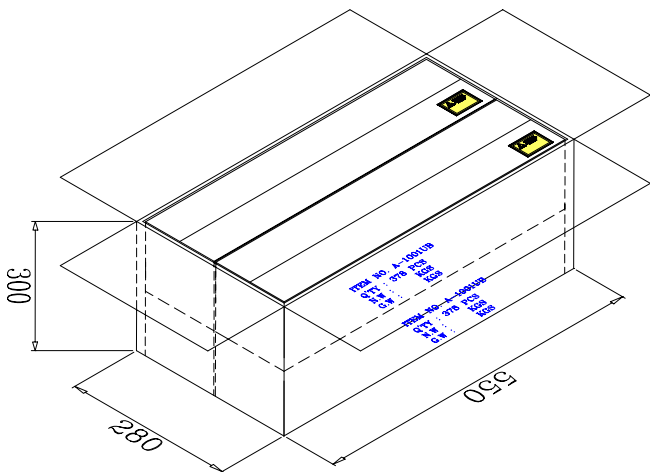
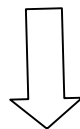

4 BOX/CTN

Experiment Item:

Item	Test Condition	Reference Standard
	Display	
OPERATION LIFE	Ta : 25 ± 5°C IF : 10 mA PER SEGMENT TEST TIME : 168HRS (-24HRS , +24HRS) 500HRS (-24HRS , +24HRS) 1000HRS (-24HRS , +72HRS)	MIL-STD-750 : 1026 MIL-STD-883 : 1005 JIS C 7021 : B-1
HIGH TEMPERATURE HIGH HUMIDITY STORAGE	Ta : 65°C ± 5°C RH : 90~95%RH TEST TIME : 240HRS ± 2HRS	MIL-STD-202 : 103B JIS C 7021 : B-1
TEMPERATURE CYCLING	85°C ~ 25°C ~ -35°C ~ 25°C 30min 5min 30min 5min 10CYCLES (COB : Thot : 65°C Tcold : -25°C)	MIL-STD-202 : 107D MIL-STD-750 : 1051 MIL-STD-883 : 1010 JIS C 7021 : A-4
THERMAL SHOCK	85°C ± 5°C ~ -35°C ± 5°C 10min 10min 10CYCLES (COB : Thot : 65°C Tcold : -25°C)	MIL-STD-202 : 107D MIL-STD-750 : 1051 MIL-SYD-883 : 1011
SOLDER RESISTANCE	T , sol : 260°C ± 5°C DWELL TIME : 10 ± 1 sec	MIL-STD-202 : 210A MIL-STD-750-2031 JIS C 7021 : A-1
SOLDERABILITY	T , sol : 230°C ± 5°C DWELL TIME : 5 ± 1 sec	MIL-STD-202 : 208D MIL-STD-750 : 2026 MIL-STD-883 : 2003 JIS C 7021 : A-2

•SOLDERING

METHOD	SOLDERING CONDITIONS	REMARK
DIP SOLDERING	Bath temperature: 260±5°C Immersion time: within 5 sec	<ul style="list-style-type: none"> Solder no closer than 2mm from the base of the package Using soldering flux, "RESIN FLUX" is recommended.
SOLDERING IRON	Soldering iron: 30W or smaller Temperature at tip of iron: 260°C or lower Soldering time: within 5 sec.	<ul style="list-style-type: none"> During soldering, take care not to press the tip of iron against the PIN. (To prevent heat from being transferred directly to the PIN.)

1) When soldering the PIN of Display in a jig that the package is fixed with a panel (See fig.1), be careful not to stress the PIN with iron tip. When soldering Display in a condition that the package is fixed with a panel, be careful not to cling and stress the surface of Display on the panel to avoid damaging the Display.

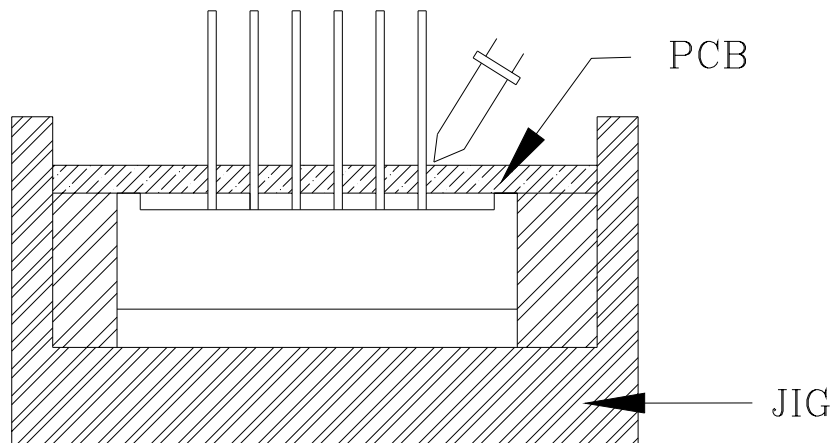

Fig.1

Regarding solution in the tinning oven for product-tinning, compound sub-solution made of tin & copper and silver is proposed with the temperature of Celsius 260. The proportion of the alloyed solution is tin 95.5: copper 3.5: silver 0.5 by percentage. The time of tinning is constantly 3 seconds.

- 2) Similarly, when a jig is used to solder the Display to PC board, take care as much as possible to avoid steering the PIN (See Fig.2).

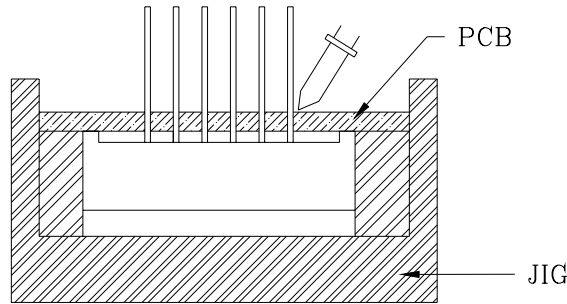

Fig.2

- 3) Repositioning after soldering should be avoided as much as possible. If inevitable, be sure to preserve the soldering conditions with irons stated above: select a best-suited method that assures the least stress to the Display.
- 4) PIN cutting after soldering should be performed only after the Display temperature has returned to normal temperature.

•LED MOUNTING METHOD

- 1) When mounting the Display by using a case, as shown Fig.3, ensure that the mounting holds on the PC board match the pitch of the PIN correctly-tolerance of dimensions of the respective components including the Display should be taken into account especially when designing the case, PC board, etc. to prevent pitch misalignment between the PIN and board holes, the diameter of the board holes should be slightly larger than the size of the PIN. Alternatively, the shape of the holes should be made oval. (See Fig.3)

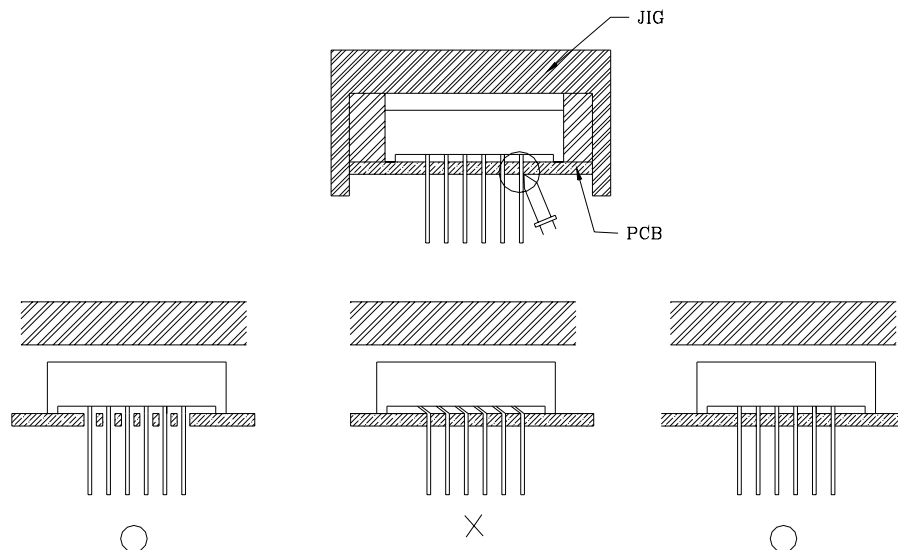

Fig.3

2) Use Display with holder made of resin (Fig.4) to position the PIN.

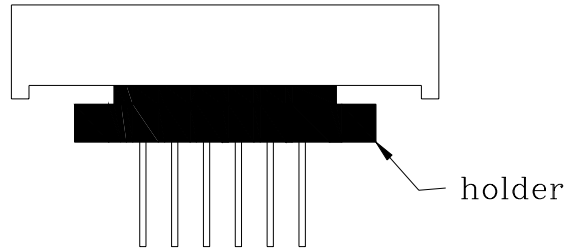

Fig.4

•FORMED LEAD

1) The PIN should be bent at a point located at least 2mm away from the package. Bending should be performed with base fixed means of a jig or pliers (Fig.5)

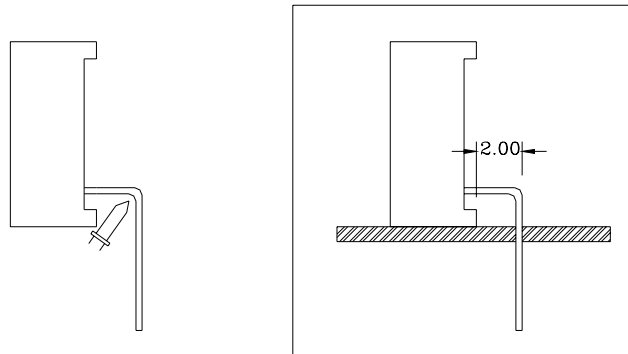

Fig.5

- 2) Forming PIN should be carried out prior to soldering and never during or after soldering.
- 3) Form the PIN to ensure alignment between the PIN and the hole on board, so that stress against the Display is prevented. (Fig.6)

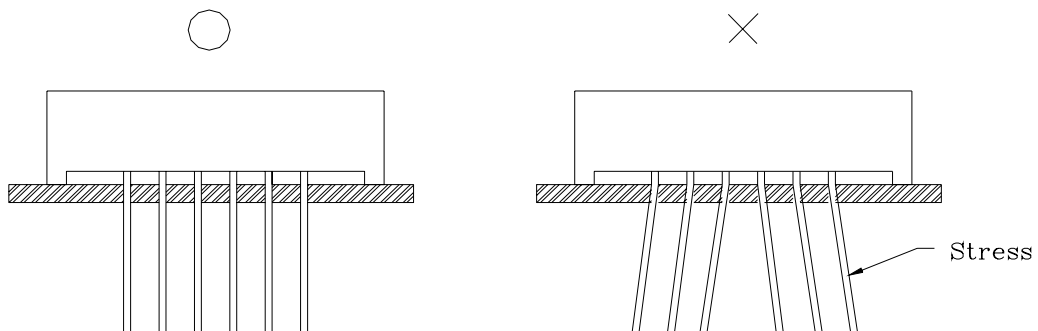

Fig.6

•LEAD STRENGTH

1) Bend strength

Do not bend the PIN more than twice. (Fig.7)

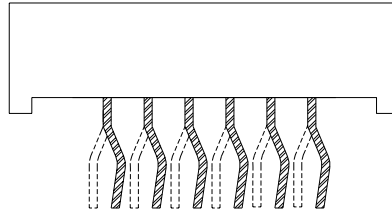

Fig.7

2) Tensile strength (@Room Temperature)

If the force is 1kg or less, there will be no problem. (Fig.8)

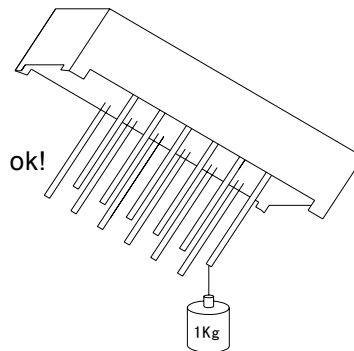

Fig.8

•HANDLING PRECAUTIONS

Although rigid against vibration, the Display may damaged or scratched if dropped. So take care when handling.

•CHEMICAL RESISTANCE

- 1) Avoid exposure to chemicals as it may attack the Display surface and cause discoloration.
- 2) When washing is required, refer to the following table for the proper chemical to be sued.

SOLVENT	ADAPTABILITY
Freon TE	⊙
Chlorothene	×
Isopropyl Alcohol	⊙
Thinner	×
Acetone	×
Trichloroethylene	×

⊙--Usable

×--Do not use.