

■Features

- High Luminous Flux
- 3mm Round Standard Directivity
- Flashing Type
- Superior UV Resistance
- Color Diffused / White Diffused
-

■Applications

- Electronic Signs And Signals
- Small Area Illuminations
- Back Lighting
- Other Lighting

■Outline Dimension

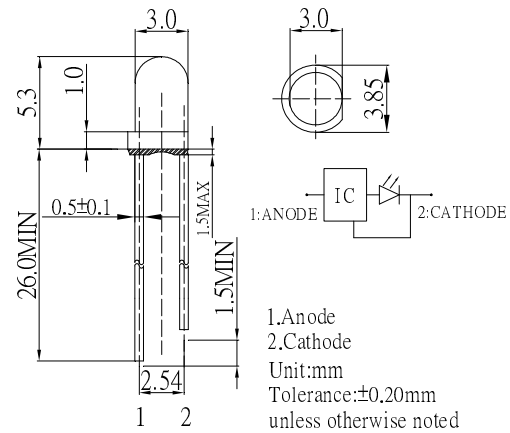

■Absolute Maximum Rating

(Ta=25°C)

Item	Symbol	Value	Unit
		W/M/B/TG /R/Y/YG/O	
Power Supply	Voltage	5	V
Duty Cycle	Duty	1/2	-
Operating Temperature	Topr	-30 ~ +85	°C
Storage Temperature	Tstg	-40~ +100	°C
Lead Soldering Temperature	Tsol	260°C /5sec	-

■Directivity

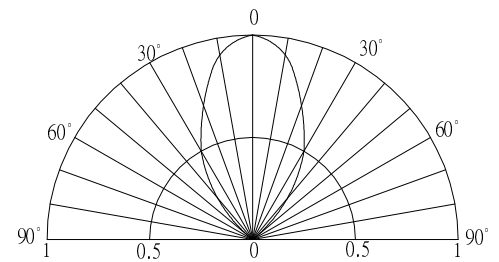

■Electrical -Optical Characteristics

(Ta=25°C)

Part Number	Color		VF (V)			Iv(mcd)*			λD(nm)*			Fled (Hz)*	2θ1/2(deg)
			Min.	Typ.	Max.	Min.	Typ.	Max.	Min.	Typ.	Max.	Typ.	Typ
			IF =20mA			IF =20mA							
OSW5DS3162A	Cool White	W	3.0	3.5	5.0	2180	3000	-	CCT:8000-18000K			1.8	60
OSM5DS3162A	Warm White	M	3.0	3.5	5.0	1560	2180	-	CCT:2700-3200K				
OSB5SS3164A	Blue	B	3.0	3.5	5.0	330	500	-	465	470	475		
OSG5DS3164A	Pure Green	G	3.0	3.5	5.0	2180	3000	-	520	525	530		
OSG8HS3164A	Yellow Green	YG	3.0	3.5	5.0	68	100	-	565	570	575		
OSY5JS3164A	Yellow	Y	3.0	3.5	5.0	220	330	-	585	590	595		
OSY5MS3164A	Yellow	Y	3.0	3.5	5.0	1120	1560	-	585	590	595		
OSO5JS3164A	Orange	O	3.0	3.5	5.0	330	500	-	600	605	610		
OSR5JS3164A	Red	R	3.0	3.5	5.0	220	330	-	620	625	630		
OSR5MS3164A	Red	R	3.0	3.5	5.0	1120	1560	-	620	625	630		

*1 Tolerance of measurements of chromaticity coordinates is ±10%

*2 Tolerance of measurements of dominant wavelength is ±1nm

*3 Tolerance of measurements of luminous intensity is ±15%

*4 Tolerance of measurements of forward voltage is ±0.1V

*5 Tolerance of measurements of frequency is ±20%